

# RS 800

Crew Mainsheet Pack V1



PLEASE FOLLOW INSTRUCTIONS IN CORRECT ORDER

# RS 800

**Crew mainsheet pack contents:**

- Mainsheet strop with 40mm block attached

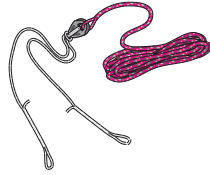

- P-clip x 2



- 520mm boom strop x 2



- 560mm boom strop x 1



- Elastic shock cord.



- Rs200 mainsheet cover

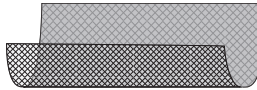

- 500mm Velcro strip x 2



- Selden eye x 1



- Monel rivet - 4.8mm x 8mm x 2



- Pan head screws - size 10 ¼ x 4 (for UJ)



- UJ

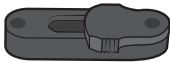

In addition to this pack, you will need:

- 5mm drill bit
- 3mm drill bit
- Phillips screwdriver
- Drill
- Tape measure
- Pencil
- 10mm spanner
- Rivet gun

**1 - Changing the mainsheet system**

a)

Remove the current mainsheet blocks and stops from the boom. Save for later.



b)

Remove the mainsheet ratchet block and save for later.

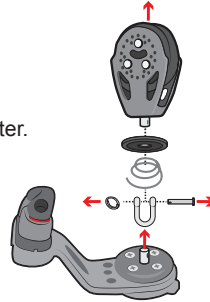

c)

Remove the dome nut from the aft-most bolt under the gunwale on each side of the boat (the U-bolt holding the aft wing bar).

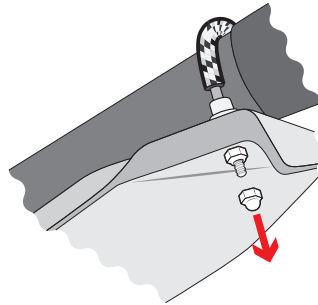

d)

Locate the new mainsheet stop (with the 40mm block on it) and P-clips in the pack. Attach the P-clips to the loops at the ends of stop.

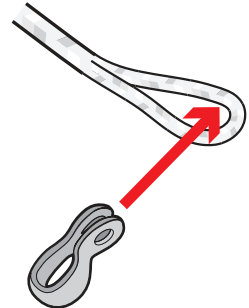
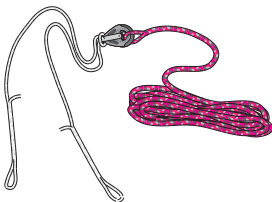

e)

Add the P-clips onto the bolts on each side of the boat. Replace the dome nuts and tighten.

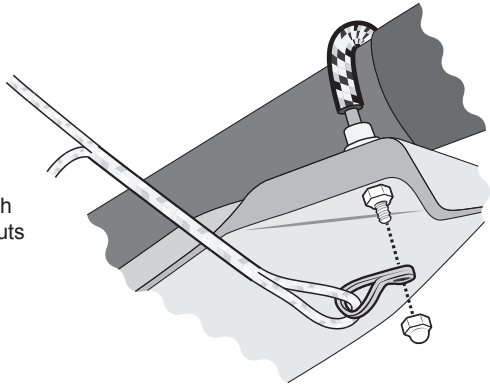

f)

Locate the new boom eye and rivets in the pack.

You will need to attach this eye to the top of the boom, with the front of the eye a maximum of 310mm from the end of the boom.

Measure the correct position then use the fitting as a template to mark the position of the holes.



g)

Drill the holes in the boom with a 5mm drill bit, then rivet the fitting into place.

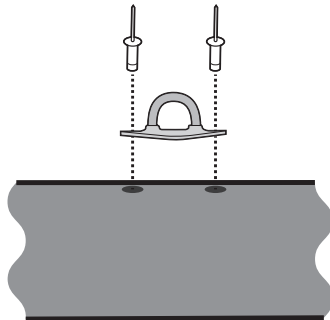

**1 - Changing the mainsheet system**

h)

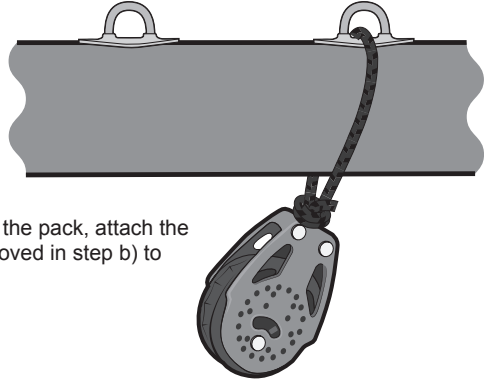

Using one of the 520mm strops from the pack, attach the original ratchet block (which you removed in step b) to the front eye on the boom.

i)

Using the other 520mm strop from the pack, attach a 40mm block to the new rear eye (which you added in **step g**).

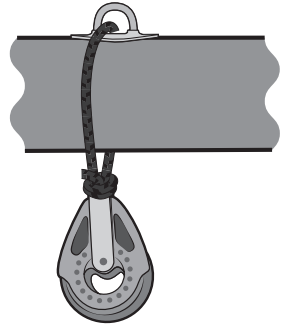

j)

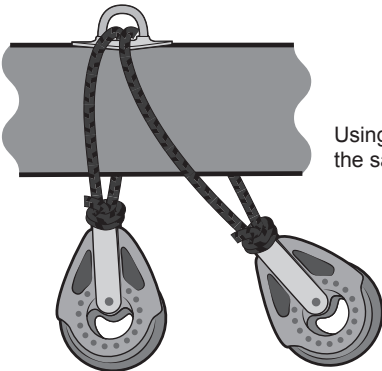

Using the longer strop, add the other 40mm block onto the same eye, in front of the block added in **step i**.

k)

The new mainsheet is spliced onto the 40mm block on the rear stop.



l)

Re-thread the mainsheet as shown.

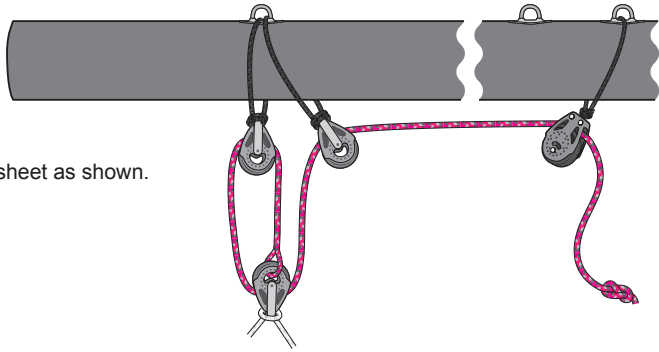

m)

Take the length of elastic shock cord from the pack and tie one end of it to the aft end of the wing on one side of the boat.

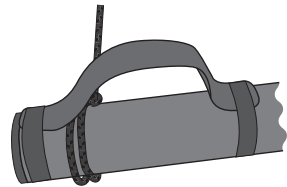

n)

Pass the end of the elastic through the centre of the block on the new mainsheet stop, then tie the other end to the aft end of the wing on the opposite side of the boat.

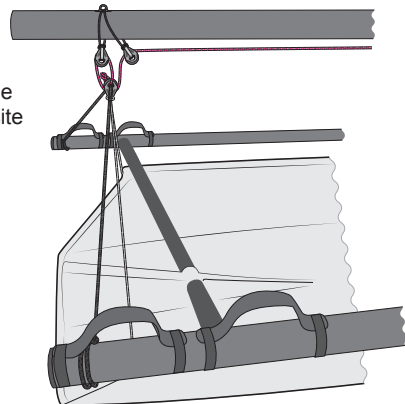
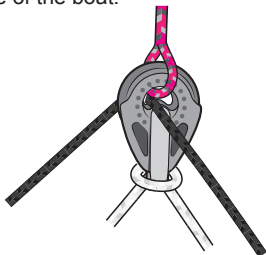

**1 - Changing the mainsheet system**

- o) The new mainsheet stop can be adjusted as necessary, but start by adjusting it so that the distance between the block and the P-clip is approximately 800mm on each side of the boat.

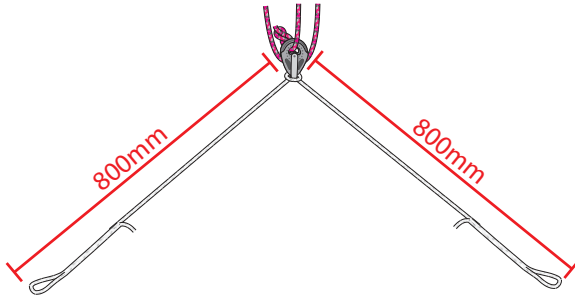
**2 - Adding the mainsheet cover**

- a) Add the mainsheet cover to the boom using the velcro strips provided. The front edge of the mainsheet cover should be 100mm aft of the unused boom eye.

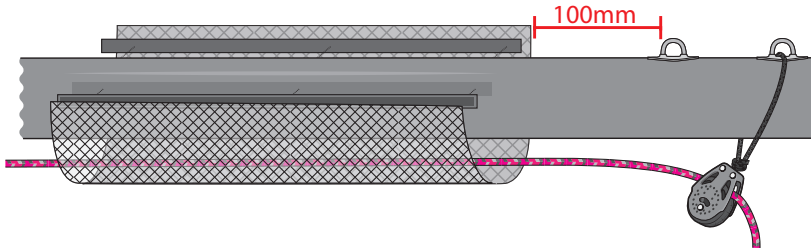
**3 - Changing the tiller extension**

- a) Remove the top universal joint fitting from the end of the tiller. Save the old fitting, you will need it for the next step.



The UJ on your tiller may not look the same as the one shown here, but the process is the same.



If the UJ on your tiller is riveted on, you will need to drill out the rivets with a 3mm drill bit to remove it.

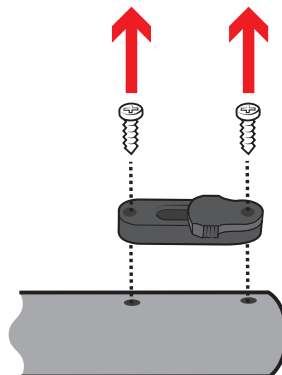

**3 - Changing the tiller extension****b)**

In the pack there is another universal joint fitting the same as the one you just removed.

These fittings will need to move onto the sides of the tiller.

Using the UJ fitting as a template, mark the hole positions then drill with a 3mm drill bit.

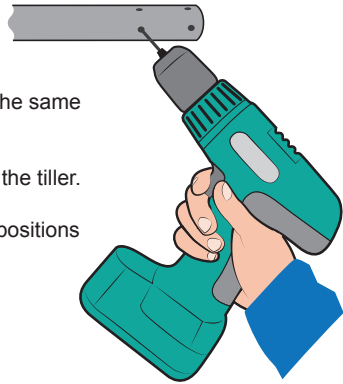
**c)**

Screw the two UJ fittings onto the sides of the tiller.

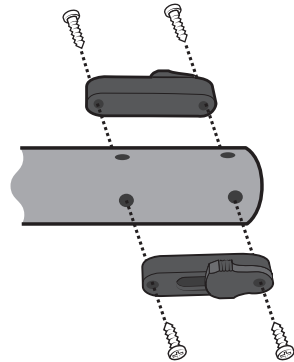
**d)**

Add the tiller extensions.

